

## 1 Correct Probe Installation

### Important Notes

- Hang probe in turbulent area of wet well
- Do not install the probe in a stagnant area or corner where grease and debris may collect. Stilling wells are not suggested.
- Ensure a minimum of 300 mm (12 inches) clearance from any surface
- Ensure bottom of probe is 12 mm (½ inch) above minimum pumping level
- Do not use the bottom sensor as earth or ground
- The probe cable must be buried (outside the well) in a separate metal conduit and shielded for correct operation of the level-sensing device
- Most pits are adequately earthed or grounded and do not require any reference rods, however PVC or Fibre Glass Tanks without pumps or metallic grounded pipe require reference rods

## 2 Probe Location

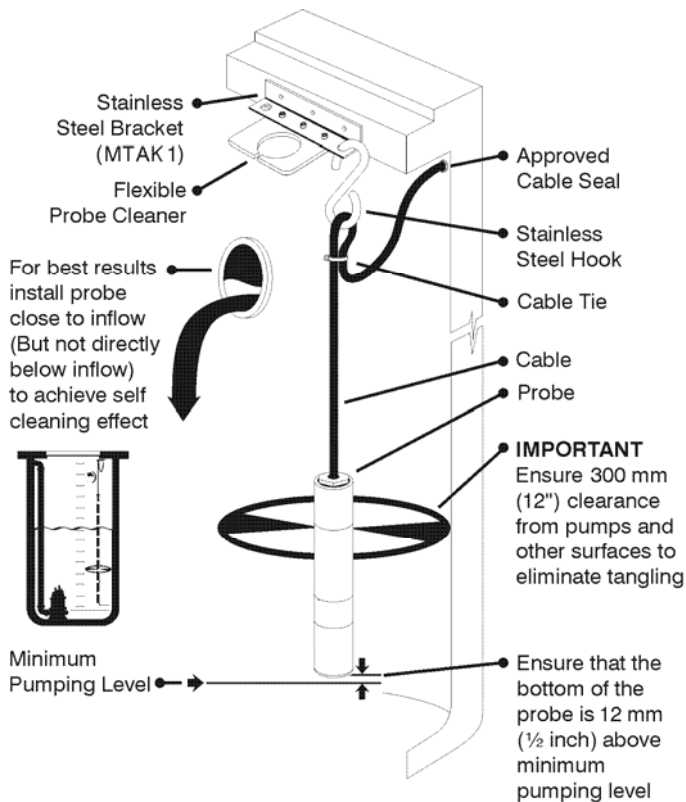

Figure 1 – Locating the probe in the vessel

The MultiTrode probe is designed to be supported on its control cable (see *Figure 1*) from the Suspension/Cleaning bracket supplied with the probe. It is desirable for the probe to be located near the inflow in a reasonably turbulent area of the wet well.

The inflow should not be allowed to run directly on to the probe, but the surface agitation of the inflow area is beneficial in keeping the probe clean. Before deciding on the probe location, the wet well should be pumped down as far as possible and the probe suspended from its approximate position to ensure that adequate clearance exists from objects in the pit.

A minimum of 300 mm (12 inches) clearance should be maintained from any conductive surfaces.

Probe sensor points are numbered from 1 to x with 1 being the sensor closest to the cabled end of the probe, and where x is the total number of sensor points.

## 3 Mounting

Fix the Suspension/Cleaning Bracket MTAK 1 in *Figure 1*, (not supplied with single-sensor probes) on to the inside of the wet well, ensuring the clearance form covers and the ladder access. To mount the probe, first thread the cable through the stainless steel hook provided. Place the hook onto the mounting bracket or eyeball and adjust the cable length until the bottom of the probe is 12 mm (½ inch) above the minimum liquid level. Fasten the cable to the hook using cable ties. Draw the loose end through the conduit to the control panel.

## 4 Cleaning

Provide sufficient slack in the cable to allow the probe to be drawn through the cleaning bracket (*Figure 1*), or taken out of the well for cleaning. MultiTrode systems are designed so that the need for probe cleaning is greatly reduced or eliminated. This is achieved by correctly positioning the probe and selecting sensitivity on the level controller.

## 5 Accessories

### MTAK 2 Extended Mounting Bracket

The MTAK 2 (*Figure 2*) is an optional extra. It is made from 2.5mm (1/8 inch) 316 stainless steel and can be used with all multi-sensored probes to give a greater, free-swinging area. It has an in-built squeegee blade style probe cleaner and includes stainless steel hook and cable ties.

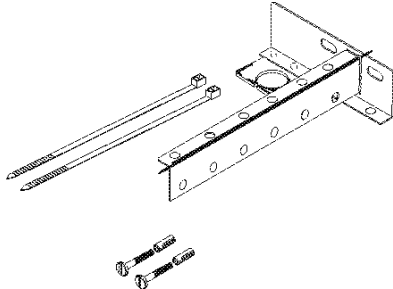

*Figure 2 – MTAK 2 Extended Mounting Bracket Kit*

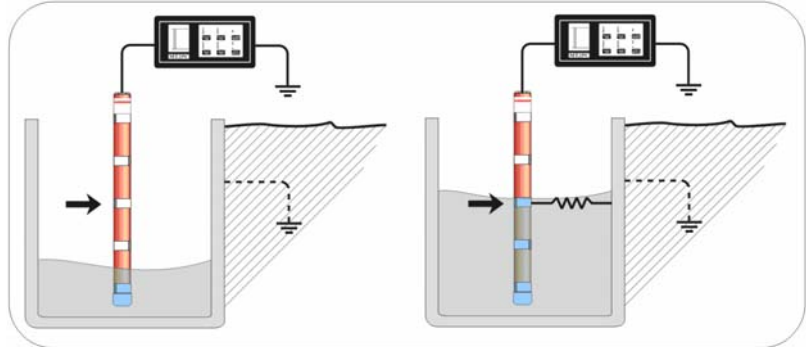

*Figure 3 – How the probe works*

## 6 How the MultiTrode Probe Works

As the level rises and contacts a probe sensor, a circuit is completed through the liquid and ground. See *Figure 3* above.

If the tank is made from PVC, fibreglass or other non-conductive material and there are no metal grounded objects such as pipes or pumps within, then the system will need an earth or ground reference rod. Suggest a 6 mm (¼ inch) stainless steel rod suspended in liquid, then grounded. See *Figure 4*.

For water applications (not sewage) there is an alternative to the earth rod and that is to use a *custom* probe with an Earth Button located at the bottom of the probe. So the return path for the level signal is no longer through ground but instead back through another conductor in the probe. See *Figure 5*.

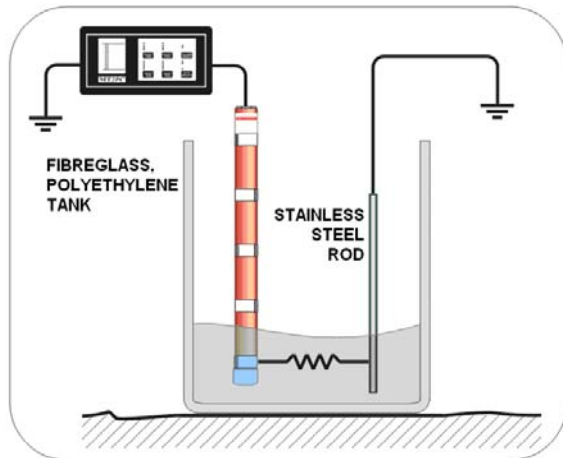

*Figure 4 – Ground Reference Rod for Non-Conductive Tanks.*

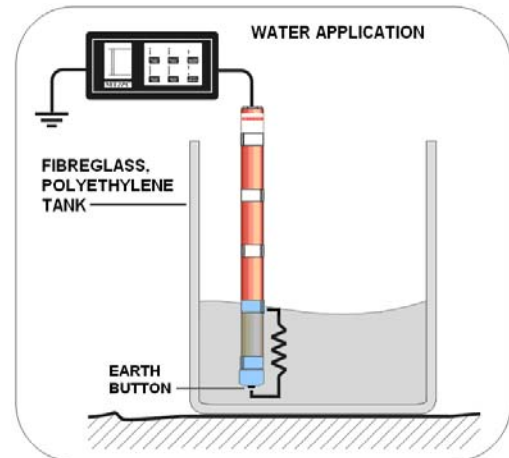

*Figure 5 – Probe with Earth Button*

## 7 Probe Construction

The probe is manufactured from uPVX moulded Housing incorporating 2 sensors of Avesta 254 SMO high-grade stainless alloy per sensing point.

### 7.1 Standard Probe

The probe has no moving parts and no electronic components inside; the probe utilizes the conductive state of the liquid to complete a circuit.

### 7.2 DuoProbe

This is a standard 10 sensor probe with the addition of a pressure transducer (4-20 mA) located at the base of the probe. This pressure sensor in conjunction with a second pressure sensor contained in the MultiSmart Pump Station Manager are used to provide a high resolution level. The 10 sensor probe allows for accurate calibration of the pressure sensors and also acts as a backup level device should the analog signal fail.

## 8 Probe Connections

MultiTrode recommends that the probe cable is directly connected to the MultiTrode relay or controller with no intermediate terminal strips or junction boxes.

The probe cable is numbered from “1 ONE” to x, where x is the total number of sensors. “1 ONE” is connected to the sensor closest to the cabled end of the probe (i.e. the highest sensor). For probes with 1 or 3 sensors, an additional orange wire is present for FailSafe (labelled “FS”). For 10 sensor probes, two additional wires are present – red (“POS”) and black (“NEG”).

Example wiring diagrams are shown below. The correct wiring is dependent on the type of probe (standard probe or DuoProbe) and the number of sensors.

### 8.1 Standard Probe - 1 and 3 Sensors

Connect as shown in *Figure 6* below. If the Fail Safe (FS) feature is not required or not present, leave the orange wire disconnected and trim or cable tie out of harms way.

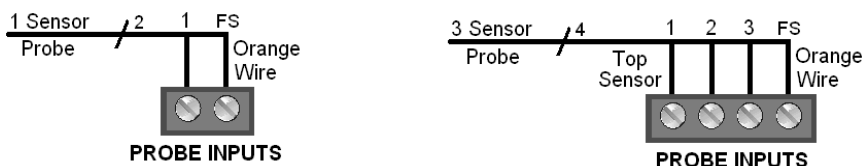

Figure 6 - Single and Three Sensor Probe Connections

### 8.2 Standard Probe – 10 Sensors

Connect as shown in *Figure 7* & *Figure 8* below. If the Fail Safe (FS) feature is not required or not present, leave the red and black wires disconnected and trim or cable tie out of harms way.

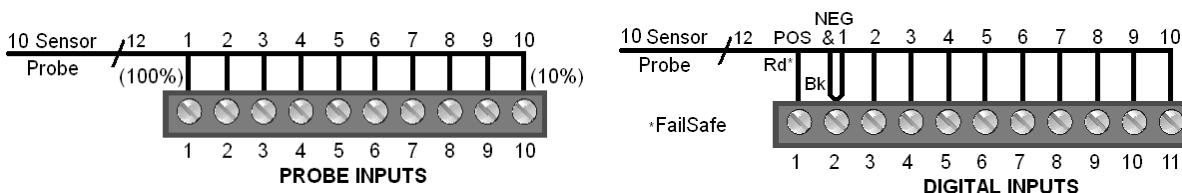

Figure 7 – Ten Sensor Probe Wiring (Excludes MultiSmart)

Figure 8 – MultiSmart Ten Sensor Probe Wiring

### 8.3 DuoProbe (MultiSmart Option Only)

Connect the probes wires from Din 2 to Din 11 and connect the red wire to the DC + power terminal and the black wire to the positive side of the analog input (e.g. 1+). The negative terminal of the analog input (e.g. 1-) is linked to the negative analog output (or to another ground), see *Figure 9* below.

There are hardware and firmware requirements which must be satisfied before the DuoProbe can be used as the level device on a MultiSmart.

- Build Version – firmware installed must be version 2.30 or higher
- HW Version – the processor board must be version PCB40001r01 or higher

To confirm if the Build and Hardware versions are correct, navigate to:

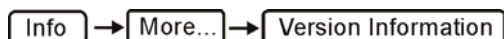

For a first time DuoProbe installation, further configuration of the MultiSmart is necessary, refer to the MultiSmart Installation & Operation Manual.

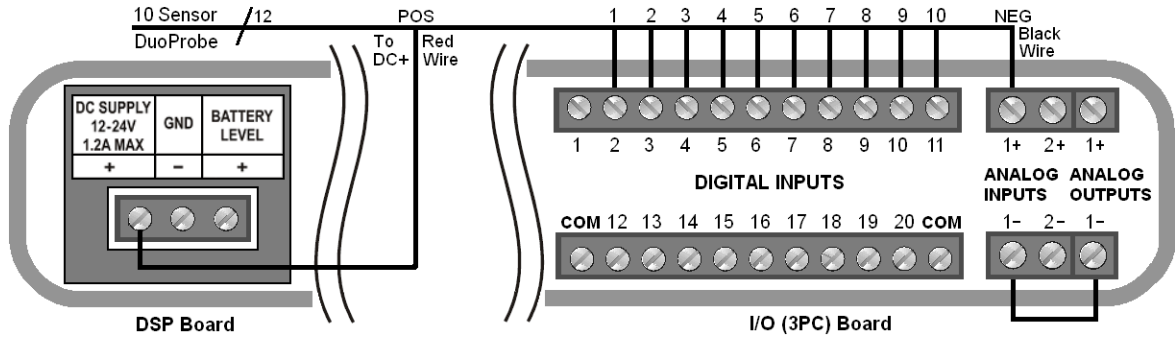
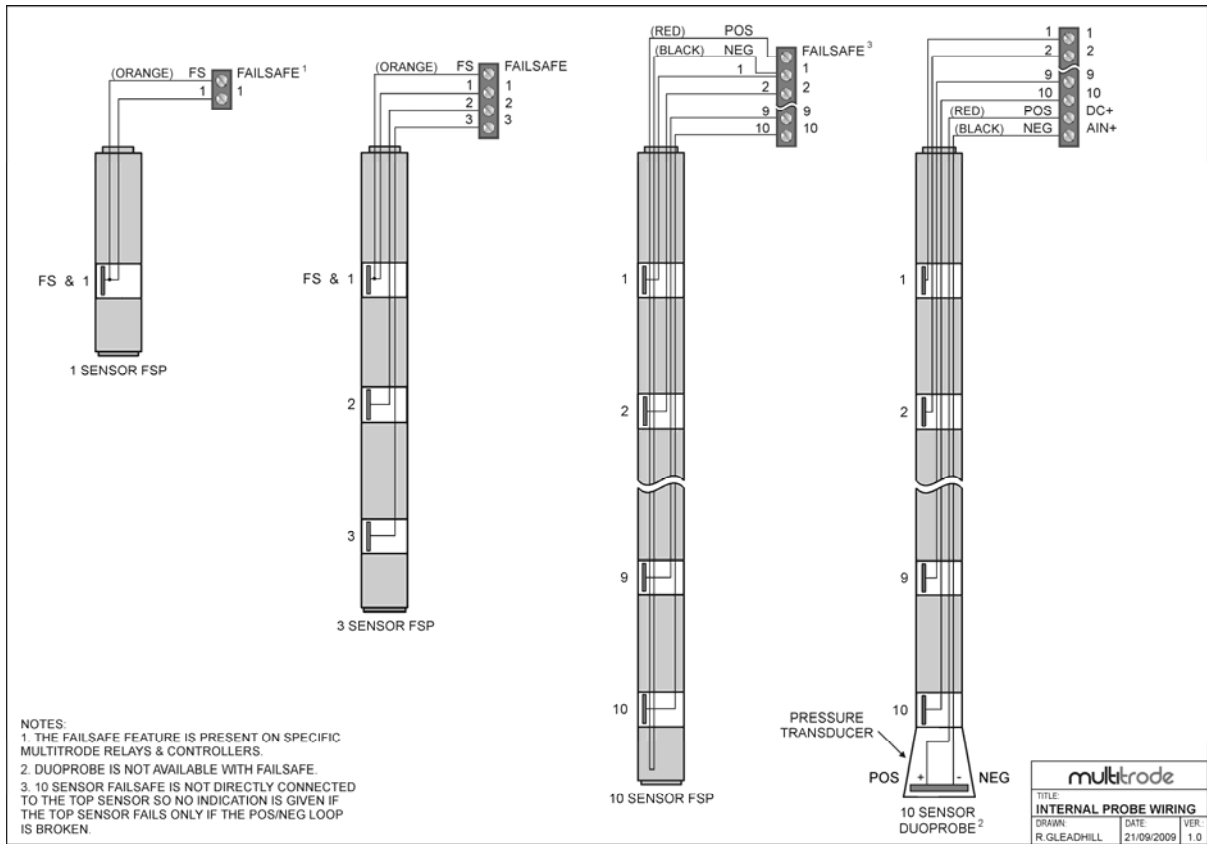

Figure 9 – MultiSmart DuoProbe Wiring

## Internal Probe Wiring



## 9 Trouble Shooting

<p><b>Controller fails to activate (when expected)</b></p>	<ul style="list-style-type: none"> <li>Remove probe connection from controller</li> <li>Short circuit the probe inputs on the controller to ground, start with p10 working your way down to p1</li> </ul>
<p><b>Does the controller activate?</b></p>	<ul style="list-style-type: none"> <li>No, Setup problem or actual faults on controller - go to trouble shooting guide or the product manual</li> <li>Yes, This means controller functional - while the probe (or probe segment) is immersed measure the resistance to ground of that sensor with a high <math>\Omega</math> resistance meter.</li> <li>Is it-opened circuit?</li> <li>Yes - end of issue – wires faulty – check for damages cables</li> <li>No – Check grounding on earth rod in pit, and grounding on Controller, check for earth continuity across installation</li> </ul> <p><i>Note: External contamination such as excess oil can insulate probe in areas such as wash down plants and workshops for diesel motors.</i></p>
<p><b>Pumps activate prematurely</b></p>	<ul style="list-style-type: none"> <li>Check sensitivity setting on controller. Set to next lowest setting.</li> </ul> <p><i>Note: This is caused by external contaminates of sticky composition, and also very conductive – can cause premature activation in some industrial applications.</i></p>
<p><b>Excessive fat build-up on probes</b></p>	<ul style="list-style-type: none"> <li>Move probe to a more turbulent area of pit, preferably close to inflow</li> </ul>
<p><b>Probe works erratically</b></p>	<ul style="list-style-type: none"> <li>Check any junctions in probe cable, especially where moisture can penetrate.</li> </ul> <p><i>Note: Running the probe cable in the same conduit as pump power cables can cause inductance into probe cable and give false readings.</i></p>
<p><b>High alarm activates after some delay when sensor is immersed</b></p>	<ul style="list-style-type: none"> <li>Check build-up on sensor – clean</li> </ul> <p><i>Note: This may be caused by some areas containing heavy sludge such as finals of treatment plants, the sludge can, over extended time, dry out over sensor. A delay of 20 to 60 seconds can be experienced due to moisture slowly penetrating build-up. Increasing sensitivity will also remedy the problem.</i></p>

## 10 Technical Specifications

### Operation

#### Failsafe and Conductive sensors:

Characteristic	Specification	Units	Notes
Voltage	10	VAC	1,2
Current	<1	mA	3
Maximum Voltage	22	VAC	1,4

- (1) Peak value
- (2) Supplied from controller
- (3) For controller output impedance  $Z_o=15K$
- (4) As specified in UL61010-1 for equipment installed in wet locations with accessible parts. It should be verified that this value is safe for the intended application and that any other applicable standards are consulted. The lowest voltage from the applicable standards should be used.

#### Pressure Transducer (2 Wire 4-20mA Loop):

Characteristic	Specification	Units	Notes
Red wire	Positive		
Black wire	Negative		
Voltage range	11-28	VDC	1
Max current	22	mA	
Reverse polarity protection	100	V	
Transient protection	400	Watts	2

- (1) It should be verified that the final voltage used is safe for the intended application and that any applicable standards are consulted. The lowest voltage from the applicable standards should be used.
- (2) 10/1000us Tr/Th waveform

## Environmental:

Characteristic	Specification	Units	Notes
Max Submersion Depth	20	metres	
Minimum Liquid Temperature	0	degrees Celsius	1
Maximum Liquid Temperature	40	degrees Celsius	
Min Cable Temperature	-40	degrees Celsius	2
Max Cable Temperature	80	degrees Celsius	2

(1) Non-freezing

(2) Non-flexing

## Storage

Characteristic	Specification	Units	Notes
Min Storage Temperature	-20	degrees Celsius	
Max Storage Temperature	70	degrees Celsius	
Min Storage Humidity	5	%	
Max Storage Humidity	95	%	1

(1) Non-condensing